

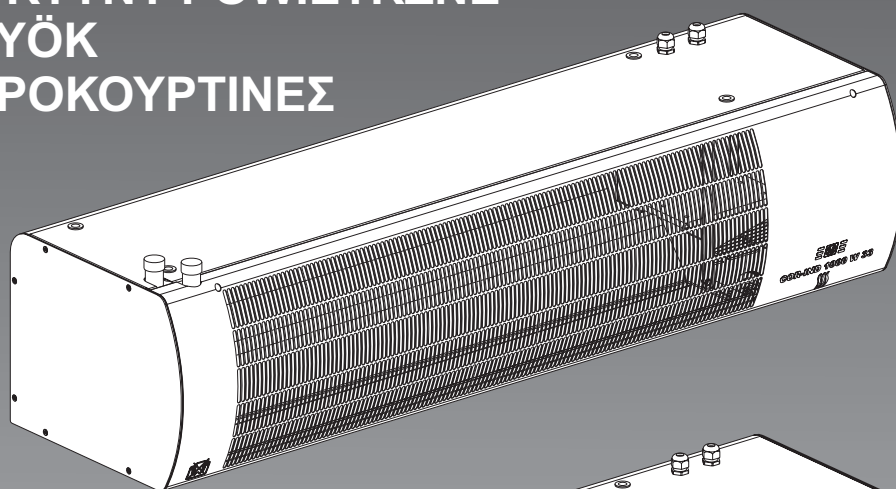

**CORTINAS DE AIRE INDUSTRIALES
INDUSTRIAL AIR CURTAINS
RIDEAUX D'AIR INDUSTRIEL
BARRIERE D'ARIA INDUSTRIALI
CORTINAS DE AR INDUSTRIAIS
INDUSTRIELLE TOR-LUFTSCHLEIER
INDUSTRIËLE LUCHTGORDIJNEN
PRZEMYSLOWE KURTyny POWIETRZNE
IPARI LÉGFÜGGÖNYÖK
BIOMHXANIKES AEPKOYPTINES**

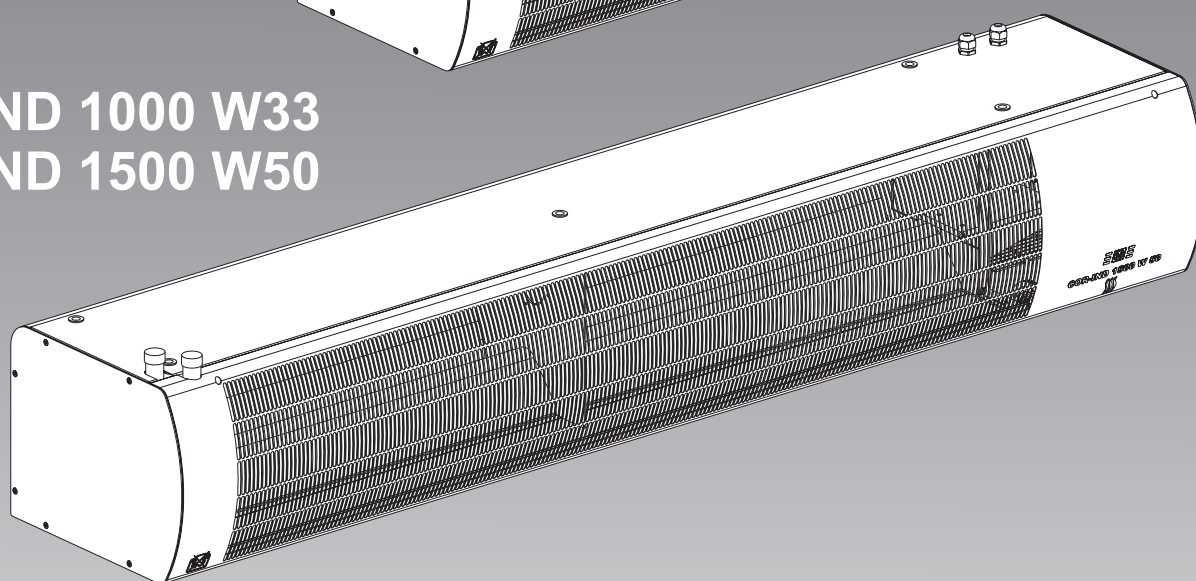

**COR-IND 1000 W33
COR-IND 1500 W50**



**MANUAL DE INSTALACIÓN. INSTRUCCIONES DE USO.
INSTALLATION AND OPERATION MANUAL.
NOTICE D'INSTALLATION ET D'UTILISATION.
ISTRUZIONI D'USO ED INSTALLAZIONE.
INSTRUÇÕES DE USO E MONTAGEM.
GEBRAUCHS- UND MONTAEANWEISUNGEN.
LUCHTGORDIJNEN.
INSTRUKCJE UŻYTKOWANIA I MONTAŻOWE.
HASNÁLATI ÉS SZERELÉSI UTASÍTÁSOK.
ΟΔΗΓΙΕΣ ΕΓΚΑΤΑΣΤΑΣΗΣ ΚΑΙ ΛΕΙΤΟΥΡΓΙΑΣ**

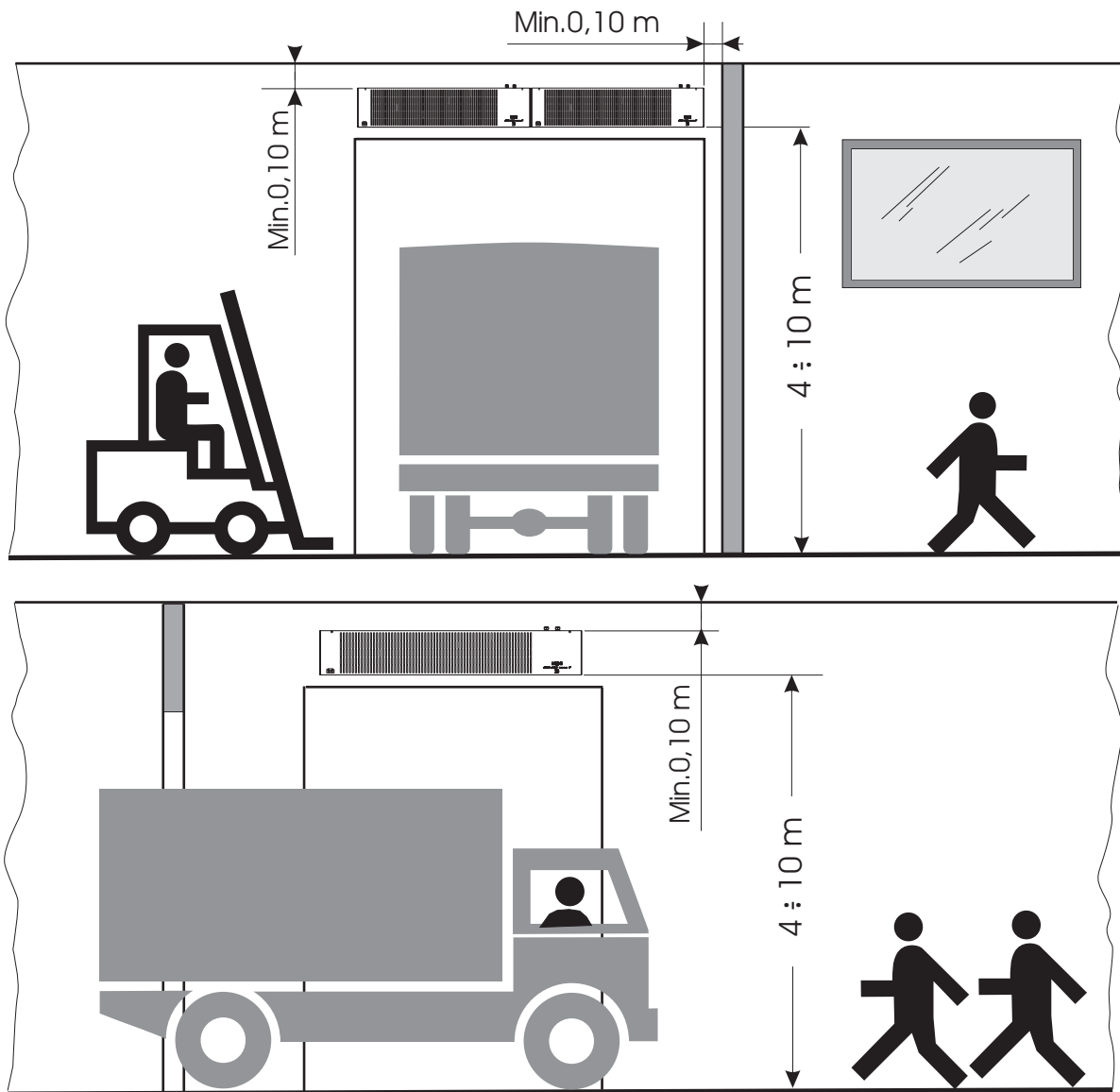
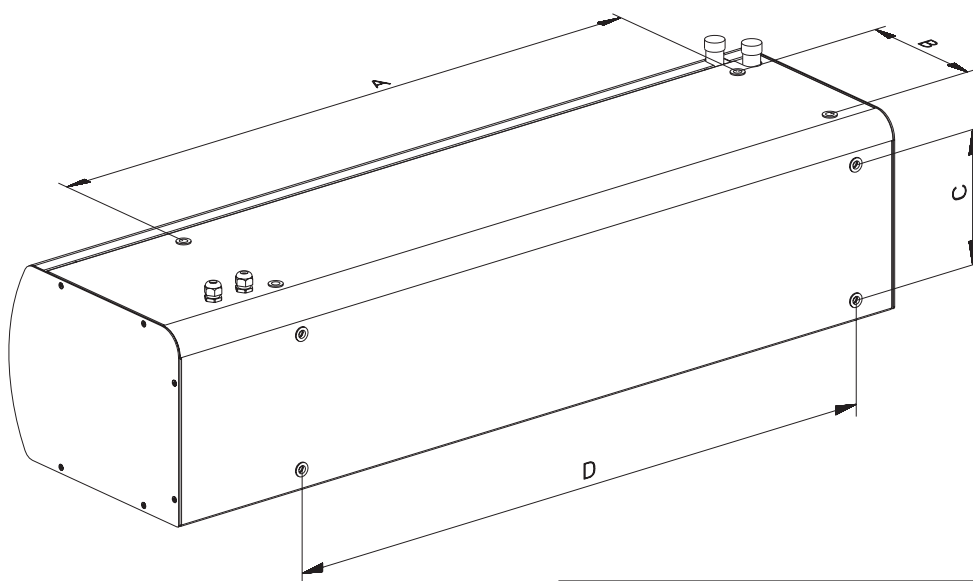
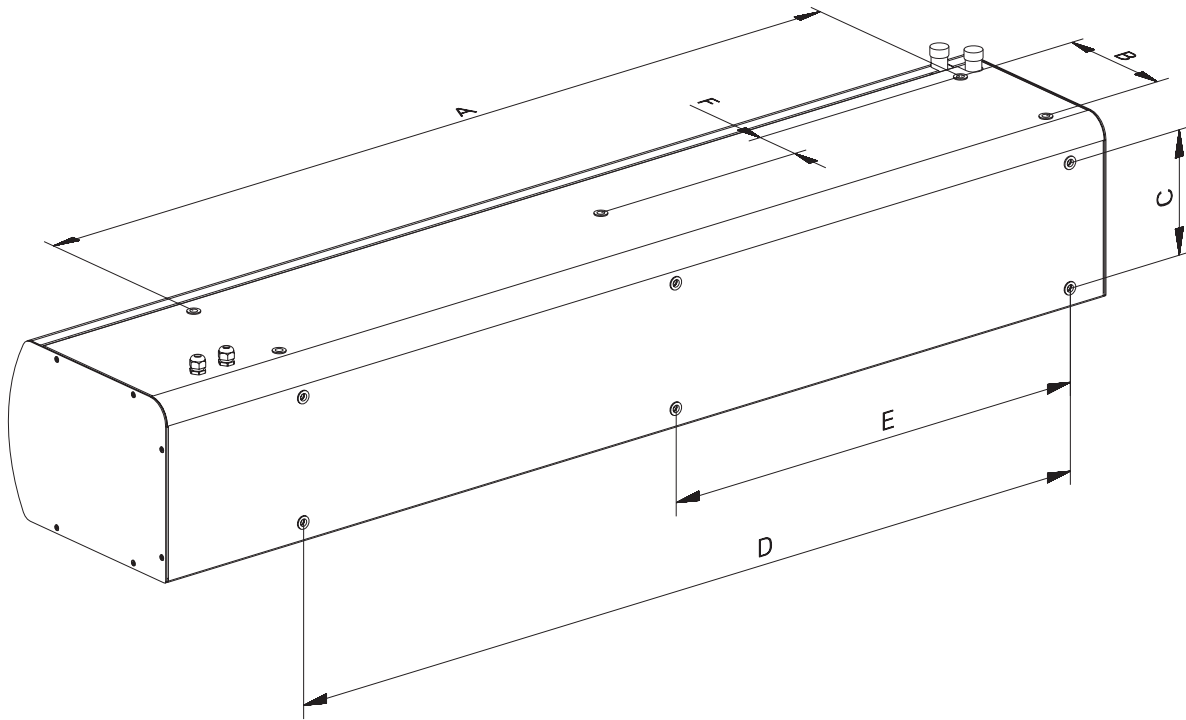

Fig.1



TIPO	A	B	C	D
COR-IND 1000 W33	1076	220	220	1076

Fig.2 (a)



TIPO	A	B	C	D	E	F
COR-IND 1500 W50	1067	220	220	1607	826	89

Fig.2 (b)

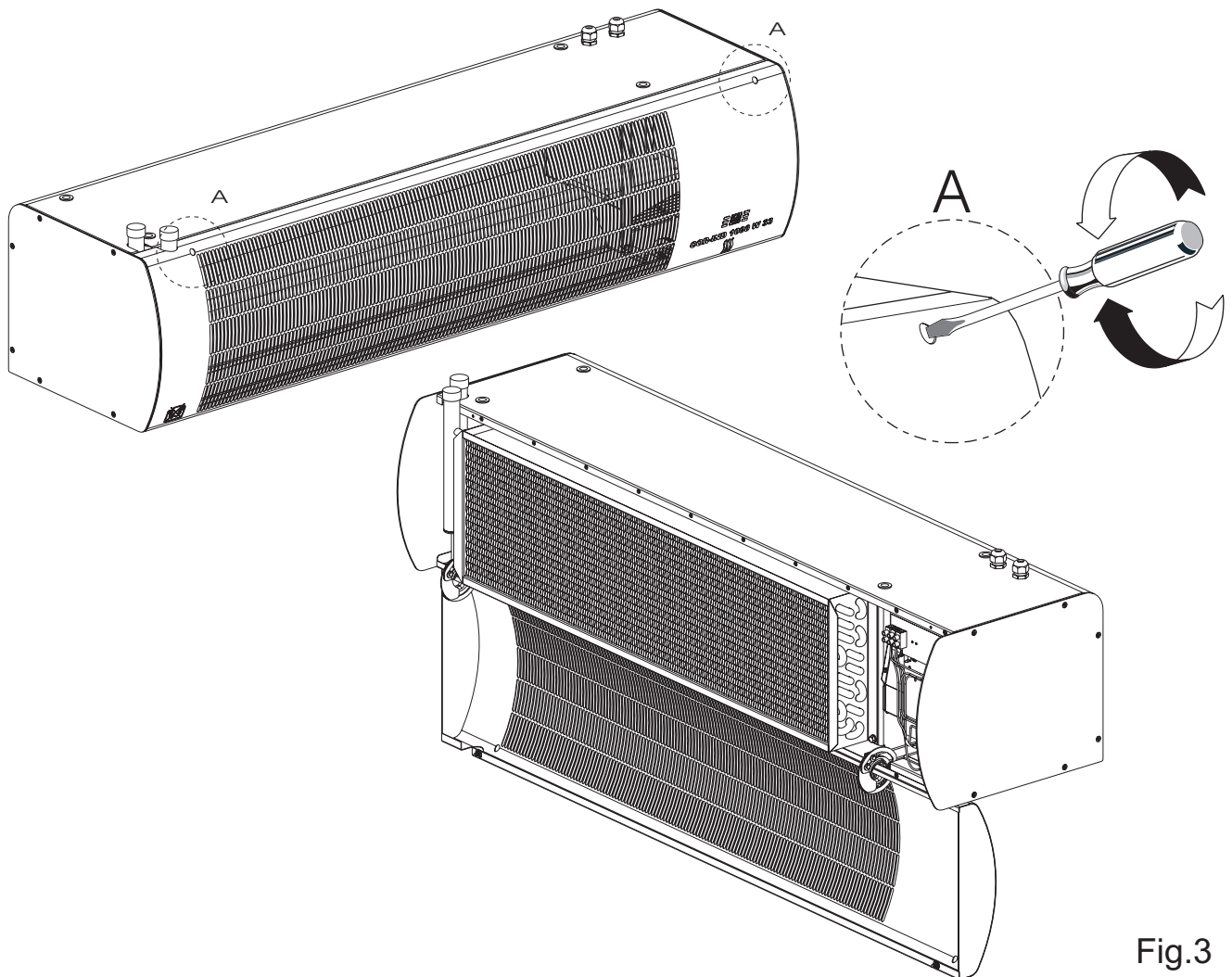

Fig.3

COR-IND 1000 W33 - COR-IND 1500 W50

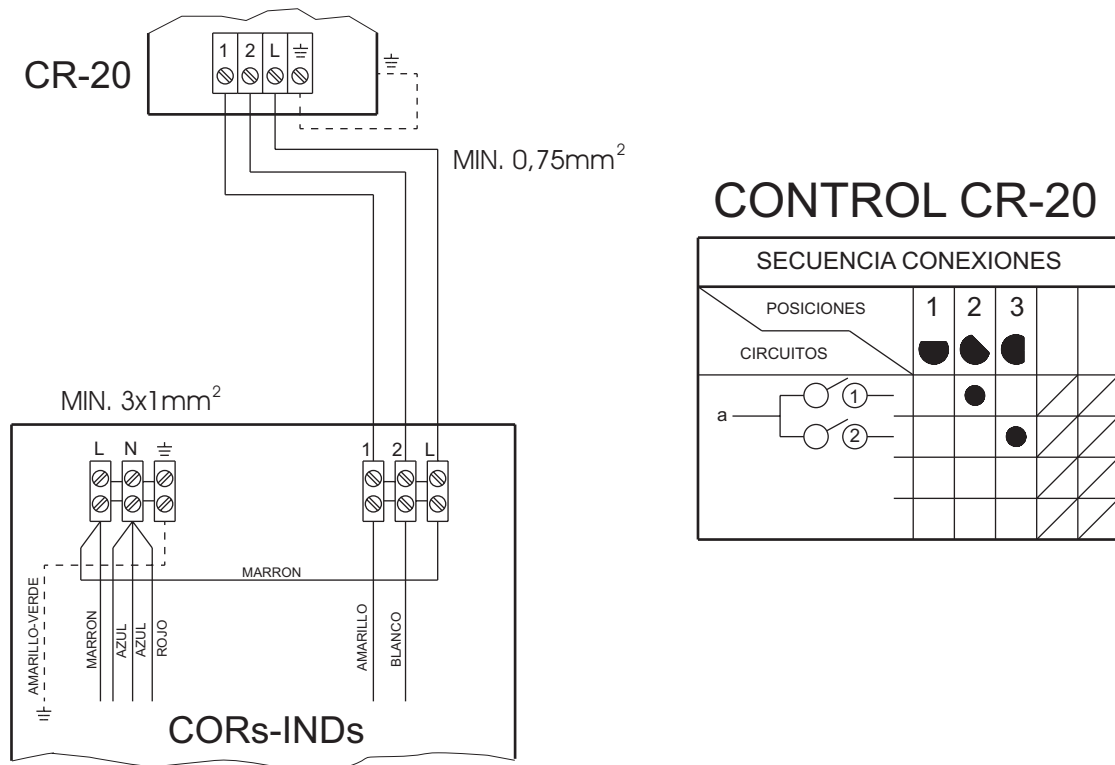

Fig.4

COR-IND 1000 W33 - COR-IND 1500 W50

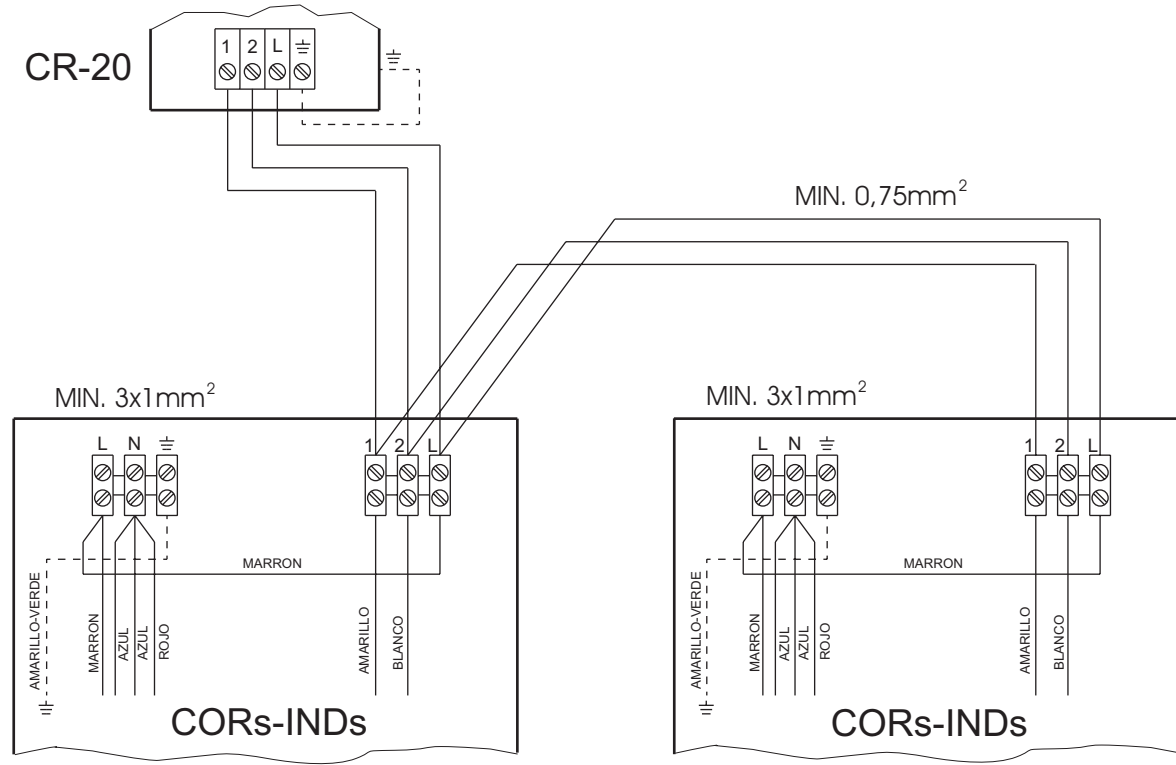

Fig.5

ENGLISH

The models in this range offer the possibility of working as hot/cold air curtains.

We advise you to check that the unit is in perfect condition when unpacking it, as any manufacturing or quality defect is covered by the S&P guarantee.

IMPORTANT: SAFETY GUIDELINES

The appliance must not be right above or below a socket.

Do not cover the unit with clothes or objects that may obstruct the airflow and cause overheating.

While in operation, the connection cable must not be in front of the air outlet.

If it is installed in the bathroom, it must be placed so that the switches or other control devices cannot be touched by anyone in the bathtub or shower.

There must not be any inflammable objects at less than 50 cm from the unit (such as window curtains, etc.).

Keep the inlet and outlet grilles clean. When cleaning them, disconnect the unit from the mains supply.

Do not manipulate the unit with wet hands.

The installation work must be carried out by an electrician.

IMPORTANT: THIS APPLIANCE MUST BE EARTHED.

The means of disconnection from the mains supply must have an opening distance of at least 3 mm in all poles.

To operate the unit as an Air Curtain, the maximum distance to the floor must not be greater than 10 metres.

The minimum distance between the Air Curtain and the floor must be 4 metres.

INSTALLATION

The unit must be fixed to a convenient

surface.

The minimum distances shown in Fig. 1 must be kept.

To install the unit, proceed as follows:

If the spiral nuts already placed in the device are used, the centres of the screws (M-12) must be marked according to the table in Fig. 2 (a) and Fig. 2(b).

To access the connection cards you must open the front grille by unscrewing the screws marked "A" in Fig. 3. To close, follow the process in reverse order.

The maximum working pressure of the water radiator must not exceed 4 Kg/cm².

The maximum temperature of the hot water must not exceed 95°C.

The water coil must not operate at temperatures of less than 5°C. When there is a risk of the temperature dropping below this limit antifreeze liquid must be used or the installation must be emptied.

The water pump must be connected to the coil via the 3/4" gas thread inlets fitted for this purpose.

ELECTRICAL CONNECTION Fig. 4

They are installed appliances. When connecting them to the mains, the standards and regulations in force in your country must be strictly adhered to.

Within the installation an electrical isolation switch must be present, to enable the installer to cut all supply lines.

Connect the unit to the mains supply, checking that the voltage and frequency are the same as those indicated on the electrical rating plate.

Use the cables with the number of wires and sections as indicated on the wiring diagram for every model.

Fix the cables with the clamp provided.

OPERATION**REMOTE CONTROL CONNECTION.**

(This control is sold separately as an accessory).

CURTAIN MODEL	REMOTE CONTROL MODEL
COR IND 1000 W33	CR-20
COR IND 1500 W50	CR-20

IF CONNECTING BETWEEN TWO OR MORE AIR CURTAINS OF THE SAME MODEL (MAX. 5 UNITS), PLEASE REFER TO WIRING DIAGRAM IN Fig. 5.

NOTE:

In the case of multiple connection, the Installer must consider the increased number of feeders based on the number of connected units.

MAINTENANCE

These air curtains do not need any special maintenance, however the following is recommended:

- 1- Keep the inlet and outlet grilles clean. Clean them with a dry cloth (avoid using solvents or abrasive detergents)
- 2- Once a year, the inside parts should be cleaned by a qualified electrician.
- 3- In order to carry out any maintenance tasks, the omnipolar cut-off device must be activated to ensure that none of the parts inside the apparatus are live.

AFTER SALES SERVICE

In the event of any problems with the unit, it is advised to contact your S&P dealer. Any manipulation of the appliance by personnel not appointed by S&P will cancel the guarantee. S&P reserves the right to modify the product without prior notice.



C/Llevant,4
Polígono Industrial Llevant
08150 Parets del Vallès (Barcelona)
SPAIN

Tel. 93 571 93 00

Fax. 93 571 93 01

Tel. int. +34 93 571 93 00

Fax. int. +34 93 571 93 11

<http://www.solerpalau.com>



Ref.: 288270002